

Applications and Key Benefits

- + Front / top terminal 12V blocs
- + Grid plates with electrolyte in gel guarantee long cycling life
Ideal for:
 - Telecom (BTS) application
 - Applications in areas with unstable power supply
- + >12 years design life
- + Deep discharge proof
- + Front terminal design reduces installation time and facilitates maintenance (except 12XL60)
- + Fits 23" power racks / cabinets (except 12XL60 and 12XL205)
- + Allows more compact battery layout
- + Fit for remote venting system
- + Non-spillable
- + Minimal gassing and maintenance free without topping-up
- + Completely Recyclable

Applicable Standards

- DIN 43539T5 - deep discharge
- IEC 60896 Part 21 - VRLA methods of testing
- IEC 60896 Part 22 - VRLA requirements
- BS 6290 Part 4 - VRLA classification
- Eurobat "Long Life" - 12 years and longer
- UL Recognized

FIAMM Manufacturing

- ISO 9001 - Quality Management System
- ISO 14001 - Environmental Management System
- OHSAS 18001 - Workplace Safety & Health

Technical Features

- Thick pasted plates with high quality lead-tin-calcium alloy for low corrosion and high rate performance
- Electrolyte immobilized in gel structure, filling completely the space between the plates top-to-bottom
- Separators with extremely high porosity and low internal resistance
- ABS IEC 707 FV0 and UL 94 V0 flame retardant plastics (LOI greater than 28%)
- Container and lid designed for unsurpassed mechanical strength made of thick walled plastics
- Female M8 terminals guarantee high conductivity, minimum installation time and maximum torque retention
- Front terminals for reduced headspace, higher energy density and compact battery layout
- High integrity post seal design to prevent electrolyte leakage and terminal corrosion
- Flame arrestors prevent sparks or flames from entering the battery
- Safety valves operate at low internal pressure
- Remote venting system available for applications which require limited gassing to be vented externally
- < 2% self-discharge per month at 20°C allows 6 months shelf life



ENDURLITE

XL 12V blocs

FIAMM XL range

Model	Nominal Voltage (V)	Capacity (Ah) at 20°C	Short Circuit Current (A)	Internal Resistance (mOhm)	Dimensions (mm)			Weight (kg)	Terminal Type
		10 hrs to 1.80 VPC	IEC 60896 21-22	IEC 60896 21-22	Length	Width	Height		
12 XL 60	12	60	1423	8.88	259	168	228	25.5	Female M8
12 XL 105	12	100	1895	6.78	126	558	230	36.0	Female M8
12 XL 125	12	120	2144	5.82	126	558	270	44.9	Female M8
12 XL 155	12	150	2519	4.97	126	558	320	54.8	Female M8
12 XL 175	12	170	3437	3.62	226	500	235	62.4	Female M8
12 XL 205	12	200	3611	3.44	260	500	235	73.9	Female M8

Note: dimensions may have a natural tolerance of ± 2 mm

Dimensions

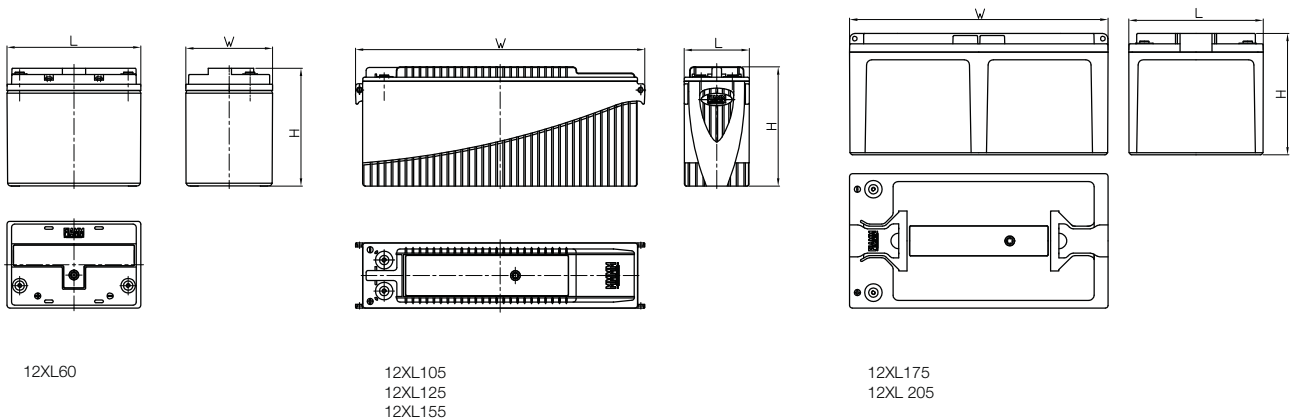

12XL60

12XL105
12XL125
12XL155

12XL175
12XL205

Electrical Characteristics

- ✦ FLOAT VOLTAGE CHARGE AT 20-25°C: Standby use 13.50-13.62 V/bloc (2.25-2.27V/cell)
- ✦ BOOST CHARGE: 2.35 V/cell
- ✦ MAXIMUM CHARGE CURRENT: 0.25 C₁₀A (i.e. for a 100Ah bloc maximum charge current is 25 Amps)
- ✦ FLOAT VOLTAGE TEMPERATURE COMPENSATION: -2.5 mV/°C/cell
- ✦ SELF-DISCHARGE AT 20°C: < 2% / month
- ✦ WARNING: in order for the warranty to be valid in all critical, frequent discharge and hybrid applications please coordinate with Fiamm Group to clarify required operating and charging settings

FIAMM S.p.A.
Industrial Batteries
www.fiamm.com
email: info.standby.asia@fiamm.com

FIAMM
+ —

Industrial Batteries